

# Turbidity Sensor Turbimess NEO



## Operating instructions

English

**A-MAN-Turbimess NEO-E-26**

Version 1.0

## TABLE OF CONTENTS

<b>1</b>	<b>General information .....</b>	<b>4</b>
1.1	Depiction of information .....	4
<b>2</b>	<b>Safety and protection measures .....</b>	<b>5</b>
2.1	General safety instructions .....	5
2.2	Intended use .....	5
2.3	Danger zones and residual danger .....	5
2.4	Equipment and accessories .....	5
2.5	Requirements of the staff .....	6
2.6	Pictograms .....	6
<b>3</b>	<b>Technical data .....</b>	<b>6</b>
3.1	Standards .....	6
3.2	Specification .....	6
3.3	Dimensions .....	7
3.4	Environmental conditions .....	7
3.5	Turbimesse NEO process conditions .....	7
<b>4</b>	<b>Product description .....</b>	<b>8</b>
4.1	Turbimesse NEO turbidity sensor .....	8
4.2	Functions .....	8
4.3	Process integration .....	8
4.4	Checking and Adjustment .....	9
<b>5</b>	<b>Delivery .....</b>	<b>9</b>
5.1	Scope of delivery .....	9
5.2	Checking the delivery .....	9
<b>6</b>	<b>Assembly .....</b>	<b>10</b>
6.1	Preparing the system .....	10
6.2	Mechanical connection .....	10
6.3	Electrical connection .....	10

<b>7</b>	<b>Parameterization .....</b>	<b>10</b>
7.1	User menu .....	10
7.2	Adjust the sensor to the medium (zeroing) .....	12
7.3	Adjust the sensor to a reference value .....	12
7.4	Output current .....	13
7.5	Switching points .....	13
7.6	Display .....	14
<b>8</b>	<b>Maintenance .....</b>	<b>14</b>
8.1	Important maintenance notes .....	14
8.2	Cleaning the lens .....	14
8.3	Maintenance plan .....	14
<b>9</b>	<b>Troubleshooting in case of problems .....</b>	<b>15</b>
9.1	No or incorrect measurement .....	15
9.2	Widely fluctuating measurement value .....	15
9.3	Output current does not match the measurement value .....	15
9.4	Switch output switches incorrectly .....	15
9.5	Display cannot be operated .....	15
9.6	Error message on the display .....	15
<b>10</b>	<b>Disposal .....</b>	<b>16</b>
<b>11</b>	<b>Repair, return &amp; warranty .....</b>	<b>16</b>
11.1	Repair .....	16
11.2	Return shipment .....	16

## 1 General information

The operating instructions enable the safe and efficient handling of the backscatter sensor **Turbimesse NEO**.

The operating instructions belong to the product and must be stored in its direct vicinity and easily accessible to the staff at all times. Before starting any work, the staff must read these operating instructions carefully and understand them.

If these operating instructions incorporate documentation from suppliers (as an attachment), Hengesbach Prozessmesstechnik assumes no guarantee for its contents, individual statements, technical data, etc.

### 1.1 Depiction of information

For simplified and safe work with these operating instructions, uniform safety instructions and symbols are used.

#### Safety instructions

Safety instructions protect against injury to persons and damage to property. The measures described for averting danger must be adhered to.

The safety instructions are structured as follows:

SIGNAL WORD	
	<b>Type and source of the danger</b> Consequences in case of non-observation Prevention measures / Prohibitive rules

The components have the following meaning:

- **Signal word:** marks the seriousness of the danger
- **Warning sign:** draws attention to the danger
- **Type and source of the danger**
- **Consequences:** describes the consequences in case of non-observation
- **Measures:** provides measures to avert the danger

WARNING	
	<b>This warning message marks a danger with a moderate risk which can result in death or severe injury if not avoided.</b>

ATTENTION	
	<b>This warning message marks a danger with a low risk which can result in minor or moderate injury if not avoided.</b>

NOTE	
<b>This note contains information regarding possible material or environmental damages which do not result in injury to persons.</b>	

## Symbols

Marks	Meaning
»	Instruction with no specified sequence
1.	Instruction with a specified sequence
•	List
→	Reference to Chapter
" "	Operating element, Push button, Button
✓	Result

## 2 Safety and protection measures

### 2.1 General safety instructions

The **Turbimesse NEO** sensor is designed in such a way that no risks can arise from using the product if the operating instructions are observed.

- Read the operating instructions first.
- Only install or operate the sensor after having read and understood all notes on its safe and proper use.
- Keep the operating instructions in a safe place in order to be able consult them at all times if required.
- Only use the sensor and its accessories if they are in good order and condition.
- Ensure proper use of the sensor. Do not use it for applications for which it is not intended (e.g. as a stepladder).
- Observe the laws, ordinances, regulations and standards applicable in the country of use and at the place of use.

### 2.2 Intended use

The **Turbimesse NEO** sensor is used in tanks or pipes. The optical part of the sensor is immersed in the process fluid to measure physical properties via the backscattering of emitted light.

The sensor must be serviced regularly.

- Prepare a maintenance schedule for the respective process.
- Only perform maintenance work described in these operating instructions.
- Changes to the sensor may only be carried out after consulting with the manufacturer.

#### NOTE

**The manufacturer is not liable for damages arising from improper or unintended use.**

### 2.3 Danger zones and residual danger

Sensors are connected to tanks and pipes which can be pressurised. Process liquid can only escape in case of negligent action or improper operation. The system or part thereof should therefore be depressurised and emptied completely before the sensor is removed.

- Before commissioning and after each maintenance, ensure that all seals and connections are complete and functional.
- Take appropriate safety precautions before touching the sensor as parts of it can adopt the process temperature.

### 2.4 Equipment and accessories

Only use tested and approved equipment and accessories.

#### Seals

If you connect the sensor to your process using an adapter, then

- » select the material properties of the process seal and the O-rings depending on the process medium and the cleaning fluid used.
- » consider the seal material's swelling capacity and resistance to acids and lyes.

## 2.5 Requirements of the staff

### Qualification

Only trained professionals may install and service the sensor!

### Protective clothing

When commissioning or servicing, the operating staff must wear goggles and appropriate protective clothing.

### Accident prevention regulations (UVV)

Please observe the work safety rules and regulations in the country and place of use!

## 2.6 Pictograms

For better orientation, pictograms and symbols are used in the operating instructions.

Pictogram	Meaning
	General warning signs

## 3 Technical data

### 3.1 Standards

The following standards were applied when manufacturing the sensor:

- EN 61326-1: 2013-7
- EN 61326-2-3: 2013-7
- DIN/EN 27027 (ISO7027)

### 3.2 Specification

Sensor specification	
Measurement range	0...100 %
Resolution	0.1 %
Accuracy	±1.5 %
Reproducibility	≤ 1 % from final value
Wavelength	850 nm
Light source	LED
Material	Stainless steel material 1.4435 (AISI 316L)
Surface finish	Ra < 0,37 μ
Lens	Sapphire ball
Supply voltage	24 V DC
Output current	4...20 mA
Switch output	Can be set to NO or NC
Input contact	+24 V DC for adjustment (zeroing)
Cable connection	5-pin M12 plug

### 3.3 Dimensions

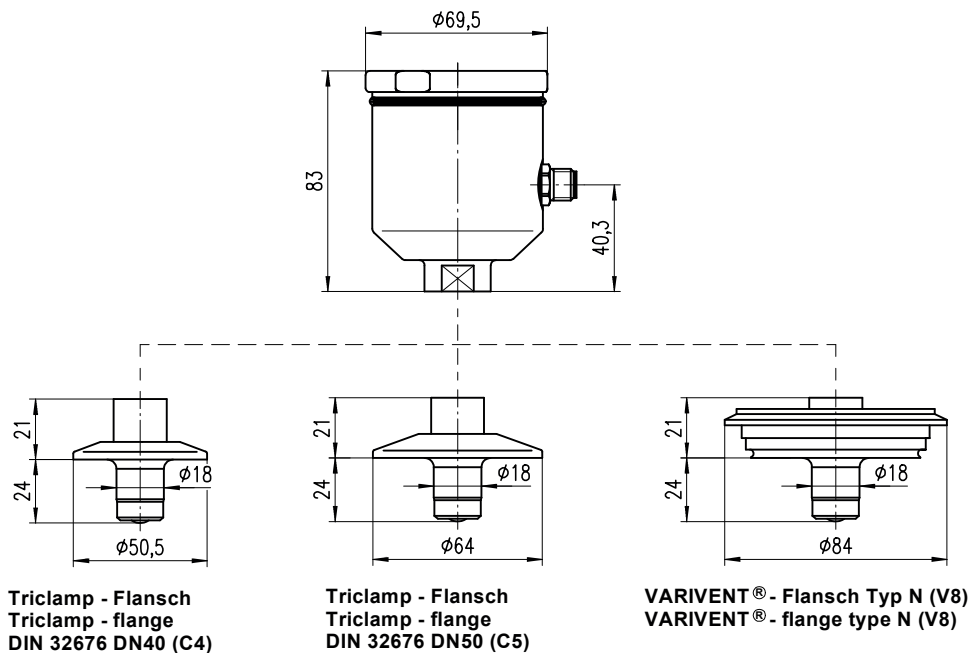

### 3.4 Environmental conditions

Ambient temperature:	-10...70°C
Transport and storage temperature:	-20...80°C

### 3.5 Turbimesse NEO process conditions

Max. permissible pressure:	20 bar
Max. permissible temperature:	100°C
Max. permissible sterilisation temperature:	141°C for max. 2 hours

## 4 Product description

### 4.1 Turbimesse NEO Turbidity Sensor

The **Turbimesse NEO** backscatter sensor enables monitoring of the turbidity of liquids for continuous monitoring of process results or safe indication of variations. It is particularly suitable for phase separation, separation control, filter monitoring and concentration measurements.

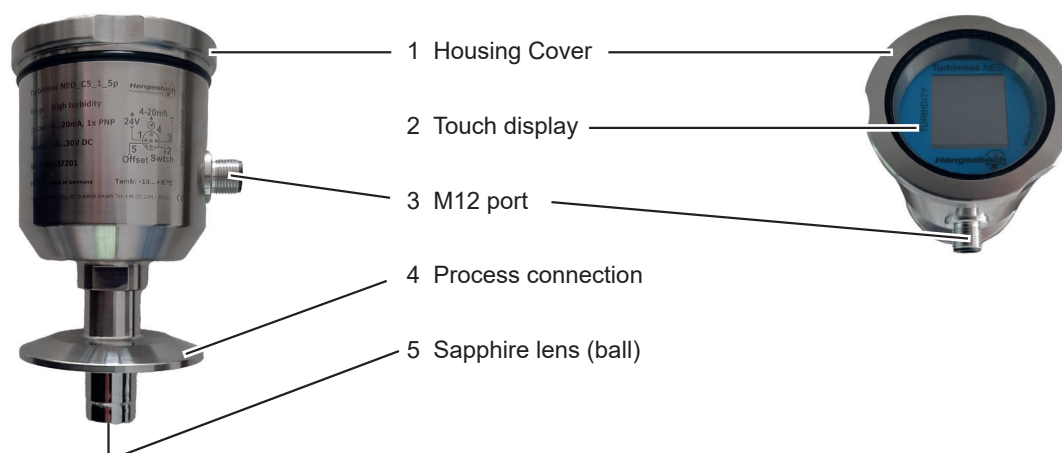

### Display

The current measurement value is shown on the display. The sensor can be configured using the touch display.

### Calibration input

The current measurement value can be set to 0 by briefly connecting a 24 V DC signal to the calibration input. With this, the transmitter can be adjusted to familiar measurement media (zeroed). The same is possible using the "Offset Val" menu function.

## 4.2 Functions

### Zeroing:

Sets the current measurement value to 0.

### Offset:

Adjusts the current measured value to a desired reference value by entering a set value.

### Display switching:

Defines which measurement value should be displayed:

- 0...4000 NTU\*
- 0...100 % turbidity

### Lower measuring range:

Defines the 4 mA point for the output current. The range can be freely selected between 0 and 100 %.

### Upper measuring range:

Defines the 20 mA point for the output current. The range can be freely selected between 0 and 100 %.

### Damping:

Attenuates the turbidity measurement value by continuous averaging.

### Switch-off point:

Defines the point at which the contact switch switched off. The range can be freely selected between 0...100 %.

### Switch-on point:

Defines the point at which the contact switch switched on. The range can be freely selected between 0...100 %.

### Switch function:

Defines the digital output function for the contact switch. You can choose between NO (normally open) or NC (normally closed).

### Switching delay:

Defines the switching delay for the contact switch. You can choose freely from a range of 0...200 seconds.

### Language:

Defines the display language.

## 4.3 Process integration

### Sensor

The **Turbimesse NEO** sensor is integrated directly into pipes or tanks.

### Transmitter

The transmitter is powered by a 24 V DC supply, has a freely programmable contact switch, and a 4...20 mA output for outputting measurement values. The measuring value can be set to 0 % via 24 V input.

### Pressure / Temperature

The **Turbimesse NEO** sensor can be used at a pressure of up to 20 bar and at a maximum process temperature of 141°C.

To protect the LED which is used, it is switched off as of a temperature of 100°C. Measurement is then no longer possible. The display shows the error message "Electricity LED". After lowering the media temperature below 100°C, the LED is reactivated and the error message disappears.

### Installation position

In principle, the sensors can be used in any location. However, you must ensure that the pipe is completely filled, and that the sensor is not set up in a place where bubbles are formed due to high turbulence of the medium. You should also observe how easily the display can be read to ensure good access and operability.

The following diagram shows the favoured locations for installing the sensor.

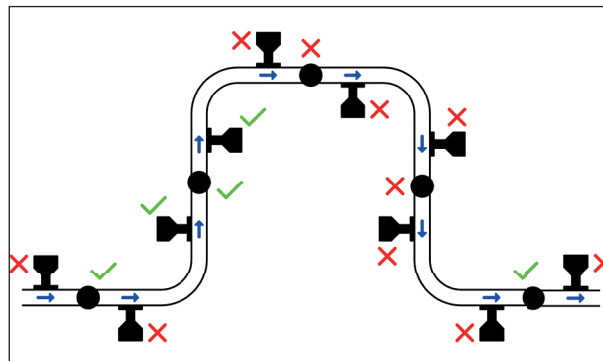

### 4.4 Checking and adjustment

Reference normals with varying backscattering values are available for checking and adjustment of the **Turbimesse NEO** sensor.



Ensure that:

- The optical sensor unit is dry and clean
- The reference normal is placed precisely on the sensor
- The marking (arrow) for the standard is aligned with the sensor connector

## 5 Delivery

### 5.1 Scope of delivery

The sensor is checked in the factory and is shipped ready for installation in packaging which protects the sensor.

The delivery includes

- **Turbimesse NEO** sensor
- Protective case for the optical unit
- Operating instructions

#### NOTE

**Keep the sensor in its packaging. It is best protected there until it is installed.**

### 5.2 Checking the delivery

Requirements:

- The packaging and device are in perfect condition.
- The sensor's identification plate corresponds with the information in the purchase order.

In case of questions please contact the manufacturer.

## 6 Assembly

### 6.1 Preparing the system

**Requirements:**

- Sufficient working space is available to operate the sensor.
- The process is deactivated.
- The tanks and/or pipes are depressurised, empty and clean.
- The connecting piece and process connector must fit together.
- The tanks and/or pipes are grounded.

### 6.2 Mechanical connection

**ATTENTION**



**Risk of injury due to escaping process liquid!**

Depending on the process liquid's properties, you may incur scalding or chemical skin burns.

» Check that the tanks or pipes to which the sensor is connected are depressurized, empty and clean.

### 6.3 Electrical connection

**Requirements:**

- Use an original cable with the correct connector.

**NOTE**

In addition, ensure that the connection cable runs only within one building, that it does not leave it and does not exceed a maximum cable length of 30 meters.

**Sensor connection:**

The color coding indicated corresponds to that used by Hengesbach Prozessmesstechnik accessories. The corresponding pin configuration can be found in the following diagram.

Pin	Description
1	DC + (24 V DC)
2	Switch output
3	GND
4	Analog output (4...20 mA)
5	Calibration (Cal. offset)

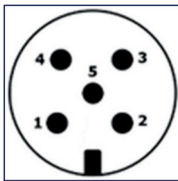

» Plug the M12-plug into the sensor connector and tighten the union nut hand-tight.

## 7 Parameterization

### 7.1 User menu

**WARNING**



Setting parameters incorrectly can result in incorrect measurement values and digital output switching points being displayed. This can have an unwanted impact on your processes.

### NOTE

Ensure that only authorised and trained staff make changes to the parameterization.

Sensor parameters can be parameterized via the touch display.



1. Touch the display to access the menu.

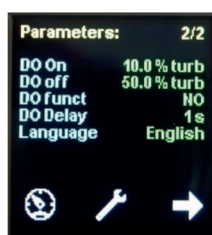

2. You can access the individual parameters and the sensor and display data by pressing the arrow symbol. If you want to configure a parameter, touch the tool symbol.

3. Then, select the appropriate setting using the arrow keys and confirm by pressing the enter symbol.



4. You can also select the desired value using the arrow keys. If a numerical value is set, it can be increased/decreased by one digit by briefly touching the respective arrow key. Keeping the arrow key pressed longer changes the numerical value by increments of 10.



5. Pressing the enter symbol confirms the value entered and exits this setting level. If no value has been changed and you wish to leave the setting menu level, press the ESC symbol.

6. You can return to the readout display by touching the speedo symbol or automatically if no entries have been made or if the display is not touched within a period of 30 seconds.

## User menu

The values in **bold** are the **standard user parameters**.

Parameter	Name	Value range	Description
Offset	Offset activation	<b>OFF, ON</b>	Activates / deactivates the setting "Offset"
Offset Val	Offset	-100.0 ... <b>0.0</b> (for unit %)	Defines the offset value
Unit	Display toggling	NTU*, %	Determines which measurement value should be displayed
AO min	Lower output limit (analog output min)	<b>0.0</b> ... 100.0 (for unit %)	Sets the turbidity value for 4 mA
AO max	Upper output limit (analog output max)	0.0 ... <b>100.0</b> (for unit %)	Sets the turbidity value for 20 mA
Damping	Attenuation	<b>0.0</b> ... 100.0	Attenuates the turbidity measuring value by returning a moving average for the set number of measuring values.
DO on	Switch-on point (Digital output on)	<b>0.0</b> ... 100.0 (for unit %)	Defines the switch-on value.
DO off	Switch-off point (digital output off)	<b>0.0</b> ... 100.0 (for unit %)	Defines the switch-off value.
DO funct	Switch function (digital output on)	<b>NO, NC</b>	NO (Normally open) = Closer NC (Normally closed) = Opener
DO delay	Switching delay (digital output delay)	<b>0</b> ... 200 s	Delays the switching by up to 200 seconds.
Language	Language settings	<b>German,</b> English, French, Dutch	Defines the display language
Display	Orientation of the display	0°, 90°, 180°, 270°	Defines the orientation of the display.

## 7.2 Adjust the sensor to the medium (zeroing)

To recognise recurring product conditions, the sensor can be adjusted to these product conditions.

1. Immerse the sensor tip into the reference liquid.
2. As soon as the measurement value is stabilised, a 24 V DC switching signal can be applied at the calibration input.

In order to activate the offset and to set the value of the reference liquid as "zero value" at the same time, the calibration input must be supplied with a voltage of 24 V DC for approx. 5 seconds.

Offset can be activated or deactivated if the voltage (24 V DC) is only applied to the calibration input for approx. 1 sec. "Zeroing" does not take place.

### NOTE

**Constant electrical voltage may neither exist at the calibration input (Pin 5, see → Chapter 6.3) nor when connecting the cable. The calibration input must be kept deenergised. Voltage (24 V DC) may only be applied short-term for the switching operations described.**

## 7.3 Adjust the sensor to a reference value

This function allows the sensor to be adjusted to a reference value (e.g., measured media samples from the laboratory or a value from a reference device).

To achieve the desired reference value, the offset value required to transfer the current measured value to the reference value must be set under the "Offset Val" menu item.

The offset value is activated/deactivated in the "Offset" menu using the ON/OFF setting.

### 7.4 Output current

The Turbimesse NEO sensor is equipped with a 4...20 mA output to return the turbidity values. The output current is configured using the following parameters:

"AO min" defines the lower measuring range and the 4 mA point.

"AO max" defines the upper measuring range and the 20 mA point.

"Damping" defines the damping affecting the display and the output current.

### 7.5 Switching points

The Turbimesse NEO sensor has a PNP switch output which is configured using four parameters.

"DO ON" defines the point at which the digital output is switched on, and "DO OFF" defines the point at which it is switched off.

The two parameters in combination determine the function of the switch output:

If the "DO ON" value is smaller than the "DO OFF" value, the digital output turns on if the measurement value is between the two points (window function).

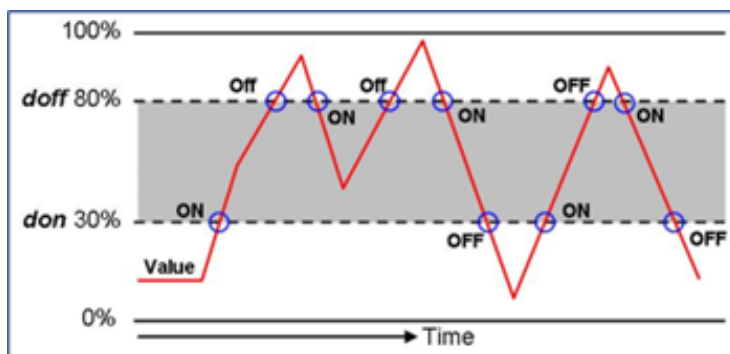

If the "DO ON" is higher than the "DO OFF" value, the output switches on if the measurement value exceeds the "DO ON" value. It only switches off again if the measurement value falls below the "DO OFF" value (hysteresis function).

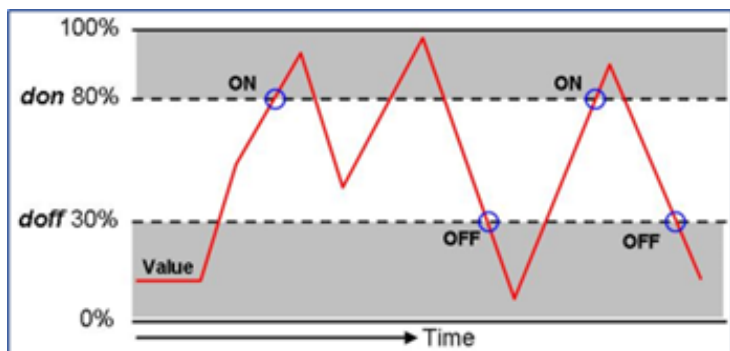

If the "DO ON" and "DO OFF" values are identical, the output switches on when the measurement value "DO ON + DO OFF" exceeds the switch value and switches off when the switch value "DO ON + DO OFF" drops below it again.

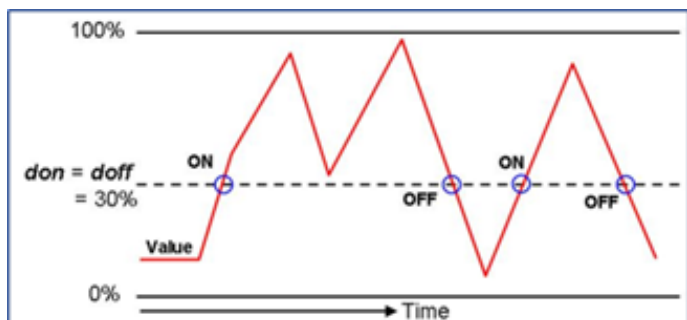

Both parameters can be set independently between 0 and 100%.

"DO funct" inverts the switch output functions.

If the value = NO, the switch output works as a closer, if the value = NC, it works as an opener.

"DO delay" delays the reaction of the switch output by up to 200 s. This value applies equally to switching the output on and off.

### 7.6 Display

The **Turbimesse NEO** sensor is equipped with a removable display. It is not possible to operate the sensor without it.

The display can be rotated in 90° increments via the "Display" setting in the menu.

Parameters can be set to the sensor via the display.

## 8 Maintenance

### 8.1 Important maintenance notes

- Prepare a maintenance plan appropriate for the respective process.
- Only trained personnel is allowed to perform maintenance work.
- Always wear appropriate protective clothing when performing maintenance works.
- Only perform maintenance work or repairs described in the operating manual.
- Changes to the design may only be carried out after consulting with the manufacturer.
- Pipes or tanks must be depressurised, empty and clean before you remove the sensor from the process.

### 8.2 Cleaning the lens

The backscatter is measured in the process by means of a sapphire lens (ball). The measurement value can be distorted by contaminants or deposits.

**Clean deposits from the lens regularly.**

1. Remove the sensor from the process connector.
2. Remove deposits from the lens.
3. Check the lens for possible damage.

#### ATTENTION



#### Risk of injury due to escaping process liquid!

- » Wear safety goggles and protective clothing.
- » Check that the tanks or pipe the sensor is being connected to is/are depressurised, empty and clean.

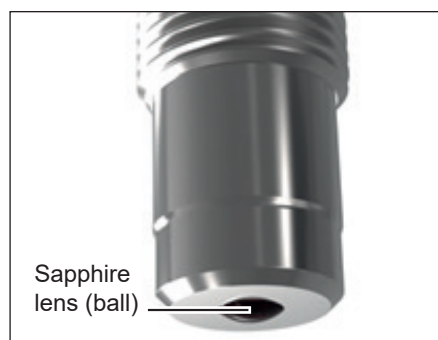

### 8.3 Maintenance plan

Perform the servicing work at recommended intervals.

Interval	Work
Every three months	» Make a visual check of the sealing of the process connector.
Once per year	» Remove the sensor and clean the lens.

## 9 Troubleshooting in case of problems

### 9.1 No or incorrect measurement

Possible cause	Remedy
No voltage to the sensor	» Check / establish electrical connection as per → Chapter 6.3
Lens is soiled	» Clean the lens → Chapter 8.2
Calibration fault	» Zero the sensor to zero with clear, distilled water or calibrate to the medium → Chapter 7.2

### 9.2 Widely fluctuating measurement value

Possible cause	Remedy
Bubbles in the system	» Attenuate the display and output current → Chapter 7.4
Sensor is not fully immersed in the process fluid	» Change the installation site

### 9.3 Output current does not match the measurement value

Possible cause	Remedy
Parameters for output current set incorrectly	» Check output current parameterization and change if necessary → Chapter 7.4
Electrical connection missing	» Check / establish electrical connection as per → Chapter 6.3

### 9.4 Switch output switches incorrectly

Possible cause	Remedy
Parameters for switch output set incorrectly	» Check parameterization of switch output and change if necessary → Chapter 7.5
Fault electrical connection	» Check / establish electrical connection as per → Chapter 6.3

### 9.5 Display cannot be operated

Possible cause	Remedy
Plug connection from display to sensor contaminated or defective	» Check and clean the plug connection. If necessary, replace the display
Display defective	» Replace the display

### 9.6 Error message on the display

Possible cause	Remedy
Data Error	» Action depends on other errors shown on the display.
COMM Error	» Action depends on other errors shown on the display.
Error!	» Action depends on other errors shown on the display.
Warning!	» Action depends on other errors shown on the display.
EEPROM Error	» Return the sensor to the manufacturer for testing.
CDU Cal Error	» Check / correct the calibration values and restart the sensor as fewer than two calibration values or selected calibration points are outside the possible range.
Sensor Overtemp	» Reduce media temperatures
LED Current	» Reduce media temperature (to protect the LEDs, they are switched off at temperatures exceeding 90°C). If the error message is also displayed at a temperature lower than 90°C, return the sensor to the manufacturer.

LED Voltage	» Return the sensor to the manufacturer
HW Error (Hardware error)	» Check the power supply
Gen Error (General error)	» Reset the sensor to factory settings or return it to the manufacturer
AO Alarm (Analog output)	» Check connector cables and plugs
Low Signal!	» The selected zero point exceeds the sensor's maximum measurement range

## 10 Disposal

### Sensor

Make sure that the sensor is free of hazardous and toxic substances. Components must be disposed of separately in accordance with their respective materials.

Please observe the valid rules and regulations concerning disposal in the country and place of application.

### Packaging

The packaging material is cardboard and can be disposed of as wastepaper.

## 11 Repair, return & warranty

### 11.1 Repair

If the sensor does not work properly anymore, please contact the manufacturer first. The manufacturer will help you with the further processing by phone and may be able to provide a solution in advance - often there is a wrong setting, which causes the device not to work properly.

However, if there is a real defect, please send the device back to the manufacturer.

	<b>Do not attempt to repair the sensor yourself. You may lose your warranty claim and possibly aggravate the existing defect.</b>

### 11.2 Return shipment

Please observe the following points when returning the sensor:

1. Secure the probe from mechanical stress.
2. Pack the device in a transport-safe outer packaging.
3. Pack electronic modules in ESD-compliant outer packaging.
4. Use the QS return form when returning the device. The form is available at [www.hengesbach.com/downloads](http://www.hengesbach.com/downloads).
5. Include a detailed description of the sensor's fault with the return shipment.
6. If necessary state what is to happen to the delivered item.

**The return address of the manufacturer is:**

	<b>Schimmelbuschstr. 17</b> <b>D-40699 Erkrath-Hochdahl</b>  Tel.: +49 (0)2104 3032-0 Fax: +49 (0)2104 3032-22  technik@hengeschbach.com www.hengesbach.com
---	--

Please note the permissible nominal pressure of the selected process connection.  
The specifications and certifications stated are only guaranteed when using original Hengesbach parts.  
The plant operator is responsible for ensuring material compatibility with the process conditions and peripherals.  
The devices are not suitable for use in potentially explosive areas or safety-relevant plant components (SIL).  
Our devices are subject to continuous development and are therefore subject to change.